



The ultimate
in flexibility.



FISCHER[®]
Engineering

Every solution customised to individual requirements.

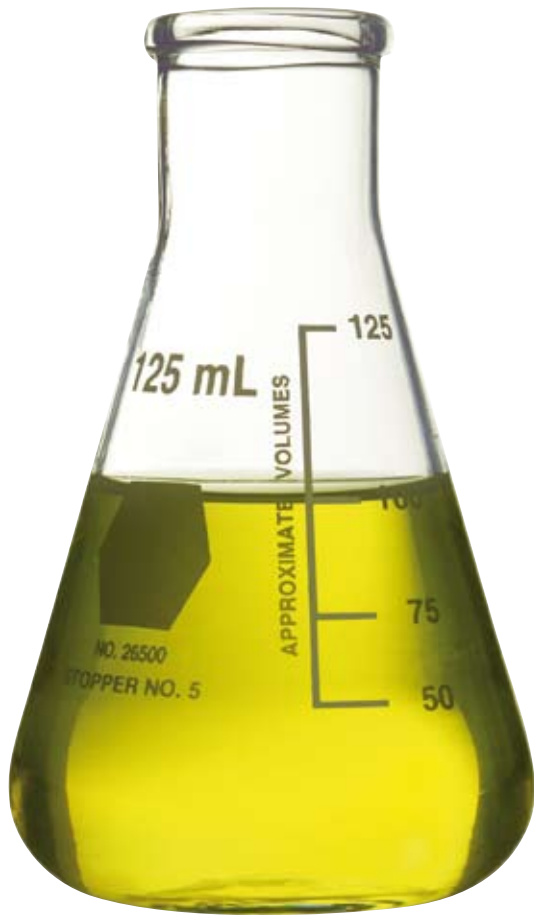

i-FISCHER Engineering® designs, develops and manufactures an extensive range of thermal process engineering products for the petrochemical industry. With decades of experience, in-depth subject knowledge and continuous product development, the company has the credentials to supply custom-built semi-automatic and fully-automatic laboratory installations and pilot plants that meet precise specifications.

We specialise in thermodynamics and chemical engineering. We design systems and equipment for the petroleum industry conforming to the international standards ASTM D 2892, D 5236 and D 1160, but we also configure one-off assemblies catering entirely to individual requirements.



The difference is clear.

The applied engineering capacity of i-Fischer sets worldwide quality standards. That's why you can expect excellent service if you come to us.

- Distillation/rectification systems
- Distillation/pilot installations for the simulation of refinery processes
- Thin film/flash evaporator systems
- Heat transfer systems
- Absorption and desorption units
- Pilot systems for solid-liquid extraction
- Pilot systems for the extraction of crude oils with light and heavy solvents - deasphalting systems
- Reactor/reaction facilities
- Microreactors for thermal cracking processes
- Adiabatic test facilities for catalyst development
- Pilot systems for delayed coking and visbreaking
- Catalytic reforming
- Hydroprocessing
- Flash equilibrium
- Phase equilibrium determination equipment



An International Centre of
Excellence for the **success**
of your business.



The know-how to get ahead.

Extensive experience, professional know-how and expert advice are fundamental to highly specialised separation technologies such as distillation and extraction.

Almost all our work is related to specific projects and geared to the special requirements of the petrochemical industry, which is why we cater almost exclusively to individual unique specifications in order to provide top-level customer service.

Following several hundred successful installations all over the world, our products and exclusive trademarks i-Fischer Engineering, FISCHER Labor- und Verfahrenstechnik, FISCHER technology, AUTODEST, LABODEST and SPALTROHR are synonymous with reliability, "Made in Germany" top-quality and cutting-edge engineering standards. The fact that we work in partnership with leading companies also guarantees our customers excellent after-sales service and permanent access to a global after-sales network.



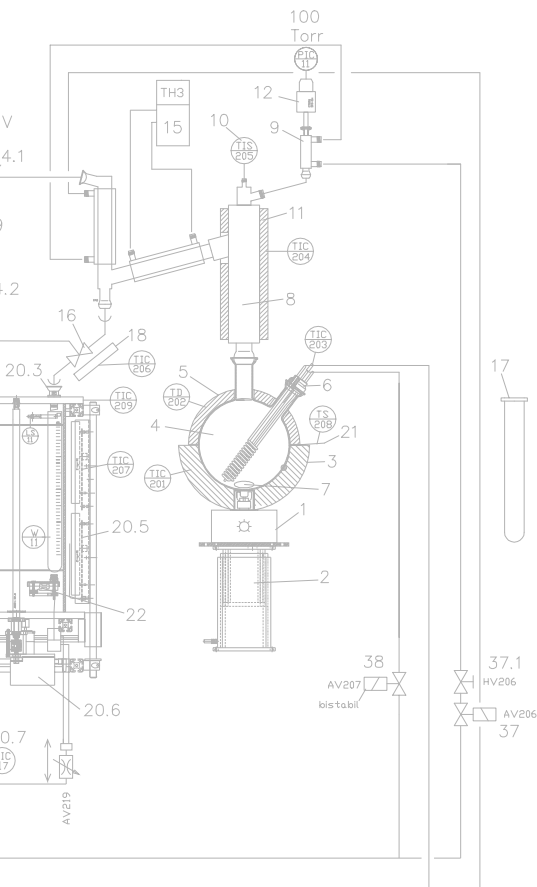

The essence of our work.

- Highest flexibility and quality
- Rationality and precision
- High separation efficiency
- Integration into existing processes
- Simple scale-up
- Potential for future expansion
- Optimum adaptability
- Compliance with international industry standards
- High-quality individual components
- Reasonable price/performance ratio
- Easy handling
- User-friendliness
- Short lead times and adherence to delivery dates
- Turnkey delivery
- After-sales service



Supreme precision for
distillates of ultra-high purity.
Experience this combination
in perfect unison.



FISCHER[®]
technology

LABODEST[®]

AUTODEST[®]

SPALTROHR[®]

FISCHER[®]
Labor und Verfahrenstechnik



i-Fischer Engineering GmbH
Dachdeckerstr. 1
97297 Waldbüttelbrunn
Germany

Tel.: +49 [0] 931-46 79 7-0
Fax: +49 [0] 931-46 79 7-29
E-mail: info@i-fischer.de
www.i-fischer.de

iFISCHER[®]
Engineering