

**OPTICAL EMISSION SPECTROMETRY (OES)**

# **Q6 NEWTON**

Fast, Reliable and 24/7 Ready

Innovation with Integrity



	C (%)	Si (%)	Mn (%)	P (%)	S (%)	Cr (%)	Mo (%)	Ni (%)	Cu (%)	Al (%)
1	0.000	0.000	0.000	0.000	0.000	0.000	0.000	0.000	0.000	0.000
2	1.00	1.00	1.00	1.00	1.00	1.00	1.00	1.00	1.00	1.00
3	1.75	1.75	1.75	1.75	1.75	1.75	1.75	1.75	1.75	1.75
4	2.00	2.00	2.00	2.00	2.00	2.00	2.00	2.00	2.00	2.00
5	2.50	2.50	2.50	2.50	2.50	2.50	2.50	2.50	2.50	2.50
6	3.00	3.00	3.00	3.00	3.00	3.00	3.00	3.00	3.00	3.00
7	3.50	3.50	3.50	3.50	3.50	3.50	3.50	3.50	3.50	3.50
8	4.00	4.00	4.00	4.00	4.00	4.00	4.00	4.00	4.00	4.00
9	4.50	4.50	4.50	4.50	4.50	4.50	4.50	4.50	4.50	4.50
10	5.00	5.00	5.00	5.00	5.00	5.00	5.00	5.00	5.00	5.00
11	5.50	5.50	5.50	5.50	5.50	5.50	5.50	5.50	5.50	5.50
12	6.00	6.00	6.00	6.00	6.00	6.00	6.00	6.00	6.00	6.00
13	6.50	6.50	6.50	6.50	6.50	6.50	6.50	6.50	6.50	6.50
14	7.00	7.00	7.00	7.00	7.00	7.00	7.00	7.00	7.00	7.00
15	7.50	7.50	7.50	7.50	7.50	7.50	7.50	7.50	7.50	7.50
16	8.00	8.00	8.00	8.00	8.00	8.00	8.00	8.00	8.00	8.00
17	8.50	8.50	8.50	8.50	8.50	8.50	8.50	8.50	8.50	8.50
18	9.00	9.00	9.00	9.00	9.00	9.00	9.00	9.00	9.00	9.00
19	9.50	9.50	9.50	9.50	9.50	9.50	9.50	9.50	9.50	9.50
20	10.00	10.00	10.00	10.00	10.00	10.00	10.00	10.00	10.00	10.00

# Built on 300 years of innovation! Q6 NEWTON

---

Over 300 years ago, Sir Isaac Newton published research into the properties of light. This included the discovery that light can be divided into its constituent wavelengths, a process also fundamental to Optical Emission Spectrometry (OES).

Nowadays, combined with modern technology the Q6 NEWTON offers a fast and reliable 24/7 industrial solution from the foundry floor to the metallurgical laboratory. Bruker is intimately familiar with metal applications, offers top-of-the-line instrumentation, and a global support network.

**We haven't changed science like Isaac Newton, but with the Q6 NEWTON we make a metallurgist's life better, faster and easier than ever before.**







# Q6 NEWTON

## Performance and reliability by design

The **Q6 NEWTON** is the superior OES solution for metallurgists and technicians to analyze alloy composition of metals. Bruker's **HighSense™** detection technology, the **SmartSpark™** source and our **RockSteady™**, the active thermal stability control system, are the key elements to achieve ultimate precision, speed and reliability in metals analysis. One push of a button unleashes the power of the **Q6 NEWTON** and provides lightning-fast measurements, excellent precision and accuracy, combined with extremely low detection limits at 24/7 operation.

# All it takes, is the push of a button

The low maintenance spark-stand of the Q6 NEWTON comes with a large and robust sample stage and an automated sample clamp. This makes correct positioning of even bulky samples of up to 120 mm height easy and reliable. A single push button provides hassle-free operation with improved operational safety. The SafeGuard™ system ensures maximum safety by permanently monitoring sample position and spark conditions.

During analysis, each of the two entrance windows of a light path is protected effectively from contamination by an ArgonShield™. Co-axial argon flow around the electrode directs the gas where it is needed: at the burn spot. This design eliminates the need for a stand by gas flow, effectively sweeps out sample condensate and facilitates the analysis of irregular and challenging samples like wires, tubes, sheets and small pieces by a complete set of adapters.

Metal analysis of all important elements in major materials is as easy as this: select the analytical program on the PC, check-in the sample ID, and press the SmartButton™.

## Q6 NEWTON – Ease-of-use and flexibility at heart.

Hassle-free, safe operation



SmartButton™ operation with color indication

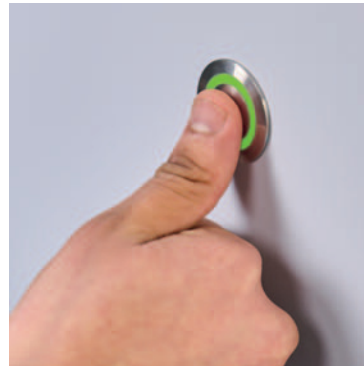

Automated sample clamp for optimal sample contact



Functional and sturdy design features







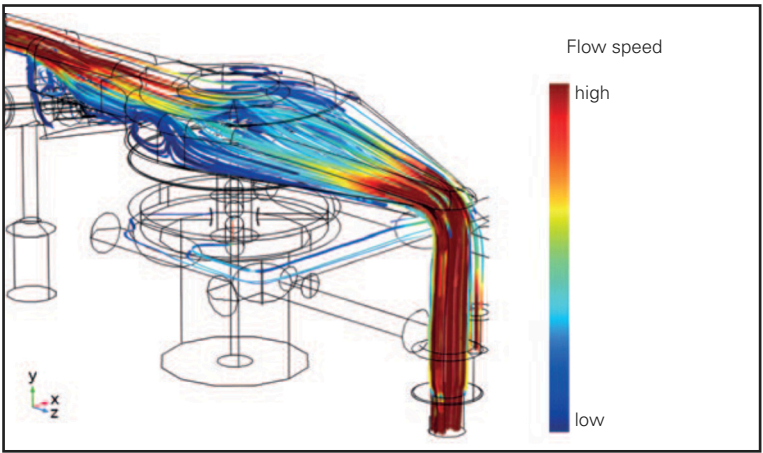

Argon flow simulation

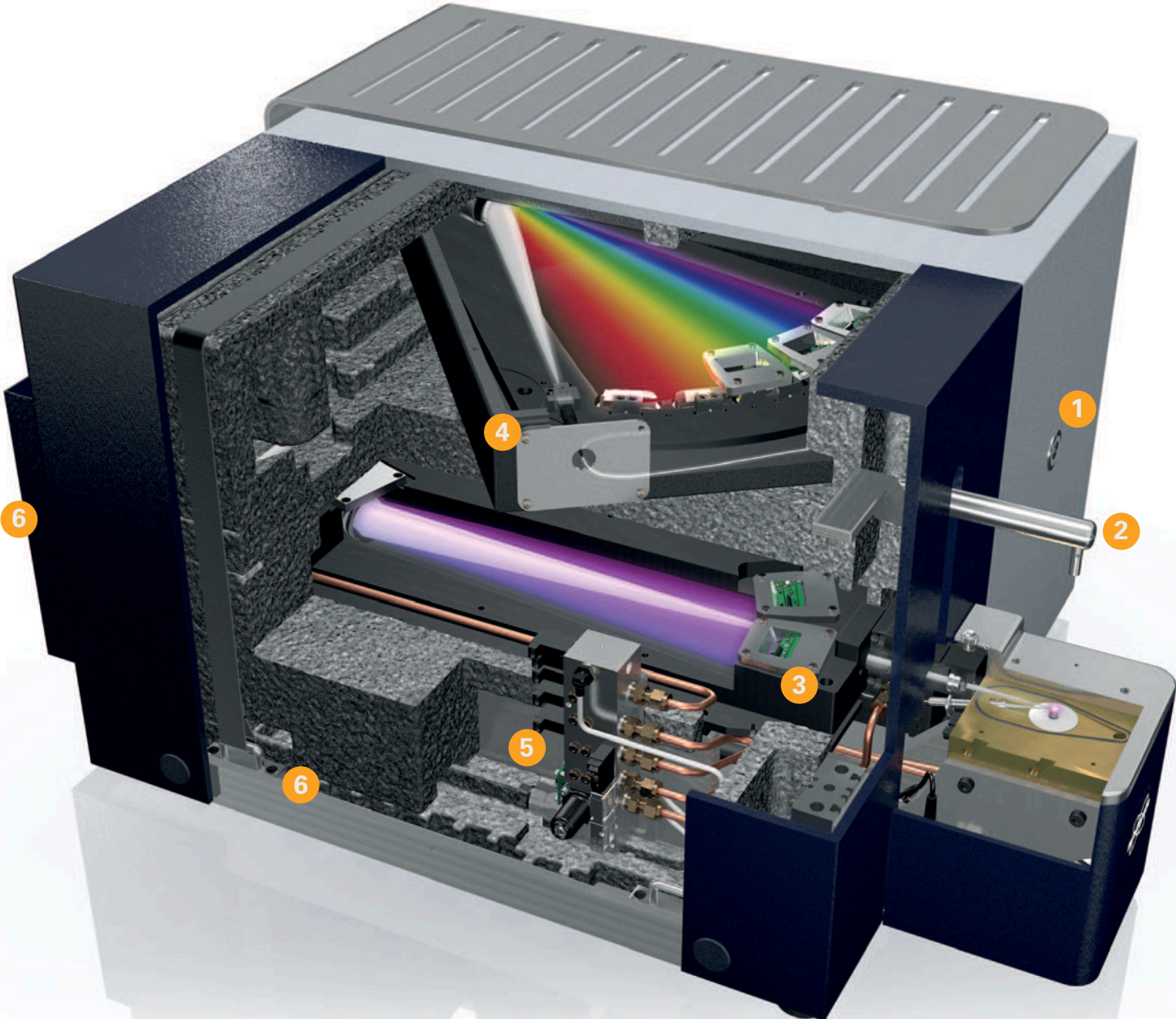



# Welcome to the future of spark emission

---

Our parallel MultiVision™ optical concept with two optics operated simultaneously – one vacuum ultra violet (VUV) optic and one visible light optic (UV/VIS) – each equipped with RockSteady™ thermal stabilization delivers outstanding long-term stability. The HighSense™ detection technology and the SmartSpark™ source together ensure high precision, low detection limits and the shortest analysis times.

## SmartSpark™

The reinvented, innovative and maintenance-free source produces ultra-stable sparks and guarantees shortest measurement times. Matrix-optimized high energy pre-sparking is used to homogenize the sample surface, reduce matrix effects and increase precision. Our material specific discharge shapes are tailored to achieve the most efficient sample ablation and emission intensities for superior analytical data quality.

## SafeGuard™

For maximum operational safety and user protection we developed a unique TÜV-approved safety board with instant shutdown in case of an operating error. In addition, SafeGuard™ constantly monitors plasma quality to indicate potential issues, such as bad argon quality, system pollution or poor sample preparation.

1

## SmartButton™

A single button acts not only as toggle start/stop button but can also trigger different actions: e.g. pressing the button between one to five seconds lowers the sample clamp without starting a measurement to test the position of irregular shaped samples. The instrument status is indicated with different colors and sequences of the button.

2

## Automated Sample Clamp

The low maintenance spark stand comes with a large and robust sample stage, making correct positioning of bulky samples easy. The automated sample clamp ensures optimal sample contact and hassle-free operation without giving up flexibility.

3

## VUV-Optics

Equipped with the most advanced HighSense™ linear array sensors, this argon purged optics covers the wavelengths from 130 – 200 nm at high resolution with spectacular detection limits. The dedicated short and direct light path, maximum tightness and a low volume purge design ensures outstanding performance with lowest possible argon consumption.

4

## UV/VIS-Optics

The air optics is connected by an optical fiber and covers the spectral range from 190 – 620 nm. It is fully equipped with HighSense™ detectors and, like the VUV-optics, connected to the new ultrafast and low-noise readout chain.

5

## Efficient Argon Budget

The new Argon distribution system ensures the most stable and economical way to feed the two ArgonShield's, the electrode co-axial flow and the VUV-spectrometer. Intelligent Argon saving routines reduce gas consumption up to 40 % compared to similar spectrometers.

6

## RockSteady™ design

Fast operational readiness, temperature stability and minimized energy consumption, thanks to active temperature management, intelligent air flow concept and thermal insulation.



Q6 NEWTON

BRUKER



Easy relocation with removable transport handles

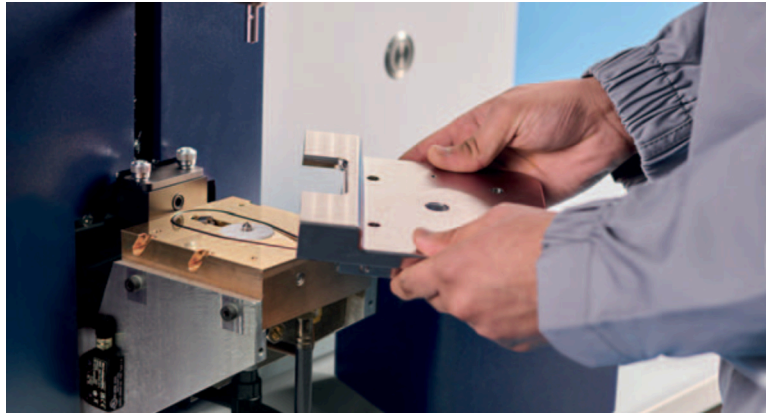

Cleaning and maintenance are very easy and absolutely safe thanks to SafeGuard™

## Build to last

The robust massive aluminum base frame of the Q6 NEWTON guarantees perfect and stable alignment of all important modules. For thermal insulation and controlled airflow the optics are embedded in isolating foam to maintain the temperature of the two optics at their ideal setpoint – precisely within a span of  $\pm 0.2$  °C.

### RockSteady™

An active temperature module ensures effective and constant cooling or heating. This results in fast operational readiness, analytical stability at almost any ambient temperature, and minimized energy consumption.

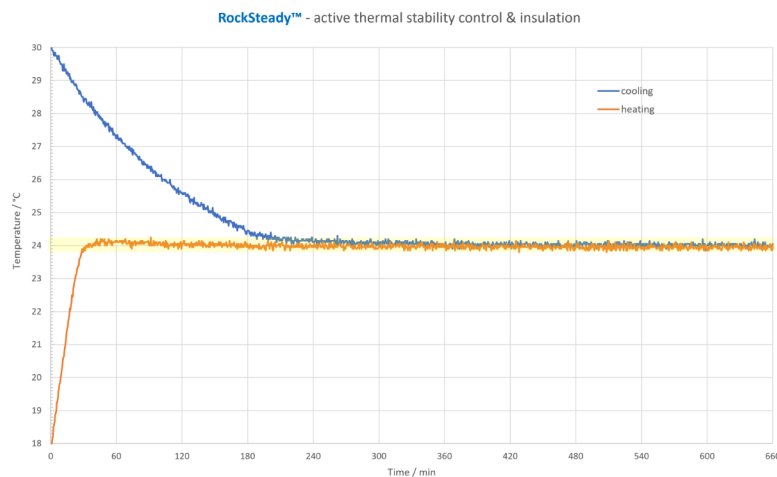

RockSteady™ translates into fast operational readiness and analytical stability at minimized energy consumption.



## Technical Data

	Specification	Benefit
<b>Spark Stand</b>	Low-maintenance spark stand with co-axial argon flow, large & robust sample stage	Minimized argon consumption and maintenance, easy analysis of wires, small pieces, and bulky samples
<b>Sample clamp</b>	Pneumatically driven, sample height: 120 mm	Hassle-free sample handling
<b>SmartSpark™</b>	Maintenance-free digital source for ultra-stable spark generation: full programmable current curves with variable discharge times down to 10 µs in a 1000 Hz sparking sequence.	Improved precision and stability
<b>SafeGuard™</b>	TÜV approved safety board with instant shutdown	Highest operational safety without interfering safety covers
<b>MultiVision™ Optical System</b>	Dual optics in optimized Paschen-Runge configuration, with RockSteady™ thermal stabilization and insulation	Fastest, simultaneous measurements with high resolution, data quality, and long-term stability
<b>VUV-Optic</b>	130 – 200 nm (Ar-purged)	Outstanding light elements performance (N, O, C, P, S,..) with high resolution and low argon consumption
<b>UV/VIS-Optic</b>	190 – 620 nm (no-purge)	Proven reliability meets lowest operational costs
<b>HighSense™ Detection</b>	Ultrafast, low noise readout chain, with high quantum efficiency by multiple state-of-the-art uncoated CMOS-sensors	Increased sensitivity, resolution and signal/noise ratio for highest data quality and low detection limits
<b>ArgonShield™</b>	Stops contamination of optical components during measurements	Permanent transparency, minimized maintenance without additional Ar consumption
<b>Argon Supply System</b>	New fast purge mode, and intelligent Argon-Saver mode Ar ≥ 99.998 % purity <sup>1)</sup> (Ar 4.8) 3 bar (± 10%) supply pressure Copper tubing (6 mm o.d.) with Swagelok® fitting	Rapid initial start-up and significantly reduced argon consumption Good performance with standard argon purity
<b>Electrical Data</b>	100 – 230 V/AC (± 10%), 50-60 Hz 16 A (240 V) or 25 A (100 V) slow blow fuse 600 VA (max), 85 VA standby, typically: 350 VA during measurement	Compatible to all worldwide power and current configurations
<b>Power supply</b>	Single phase 208 – 240 V Three phase 120 V, 230 V, 240 V; 47 – 63 Hz	Single phase 208 – 240 V Three phase 120 V, 230 V, 240 V; 47 – 63 Hz
<b>Dimensions &amp; Weights</b>	62 x 88 x 48 cm (W x D x H), ~80 kg	High performance in compact format

**Bruker AXS**  
info.baxs@bruker.com

**Worldwide offices**  
bruker.com/baxs-offices

**Online information**  
bruker.com/q6newton



bruker.com